



CB300

Brazed Plate Heat Exchanger

Working principles

The heating surface consists of thin corrugated metal plates stacked on top of each other. Channels are formed between the plates and corner ports are arranged so that the two media flow through alternate channels, always in counter-current flow. The media are kept in the unit by a brazed seal around the edge of the plates. The contact points of the plates are also brazed to withstand the pressure of the media handled.

Standard design

The plate pack is covered by cover plates. Connections are located in the front or rear cover plate. The channel plates are corrugated to improve heat transfer efficiency and to make them rigid.

Standard materials

Cover plates

Stainless steel AISI 316

Connections

Stainless steel AISI 316

Plates

Stainless steel AISI 316

Brazing material

Copper

Advantages of brazed plate heat exchangers in Industry and HVAC&R

The Alfa Laval Brazed plate heat exchangers (BHE) have several advantages over traditional heat exchangers in Industrial and HVAC&R applications.

- The high heat transfer efficiency of the BHE makes it extremely compact and also easy to install in places where space is limited.
- The unit has no gaskets and is therefore suitable in applications where temperature and/or pressure is high e.g. in district heating.
- The Alfa Laval supply system reassures that, no matter where you are on the globe, the BHE units are available with a very short delivery time.

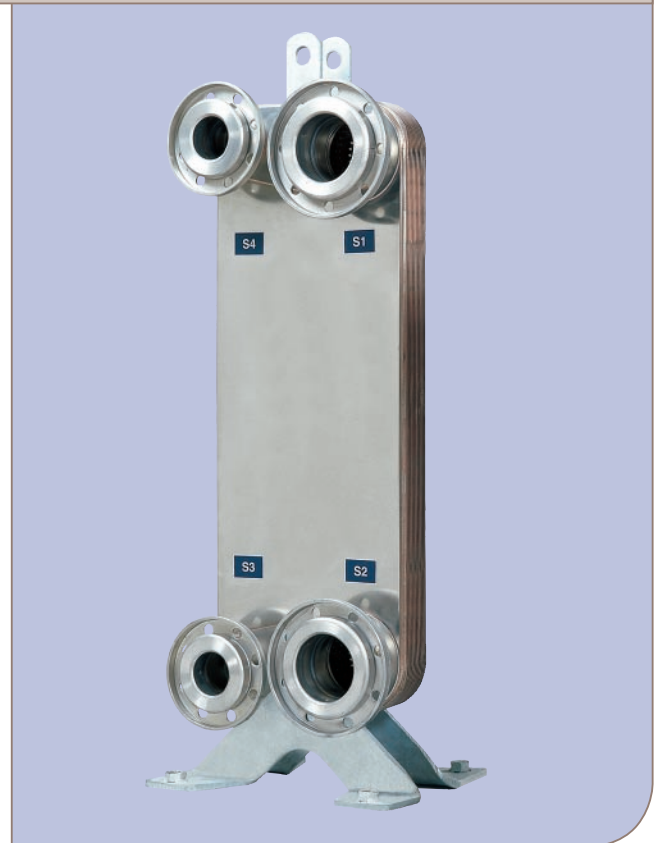

Particulars required for quotation

To enable Alfa Laval's representative to make a specific quotation, enquiries should be accompanied by the following particulars:

- flow rates or heat load required
- temperature program
- physical properties of liquids in question
- desired working pressure
- maximum permitted pressure drop

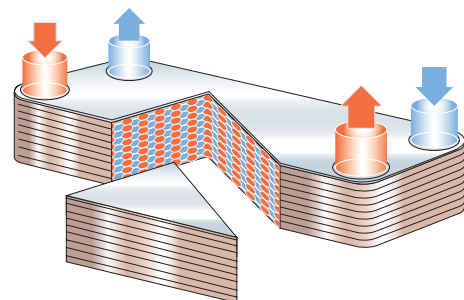

Flow principle of a brazed plate heat exchanger

Dimensions

measurements in mm

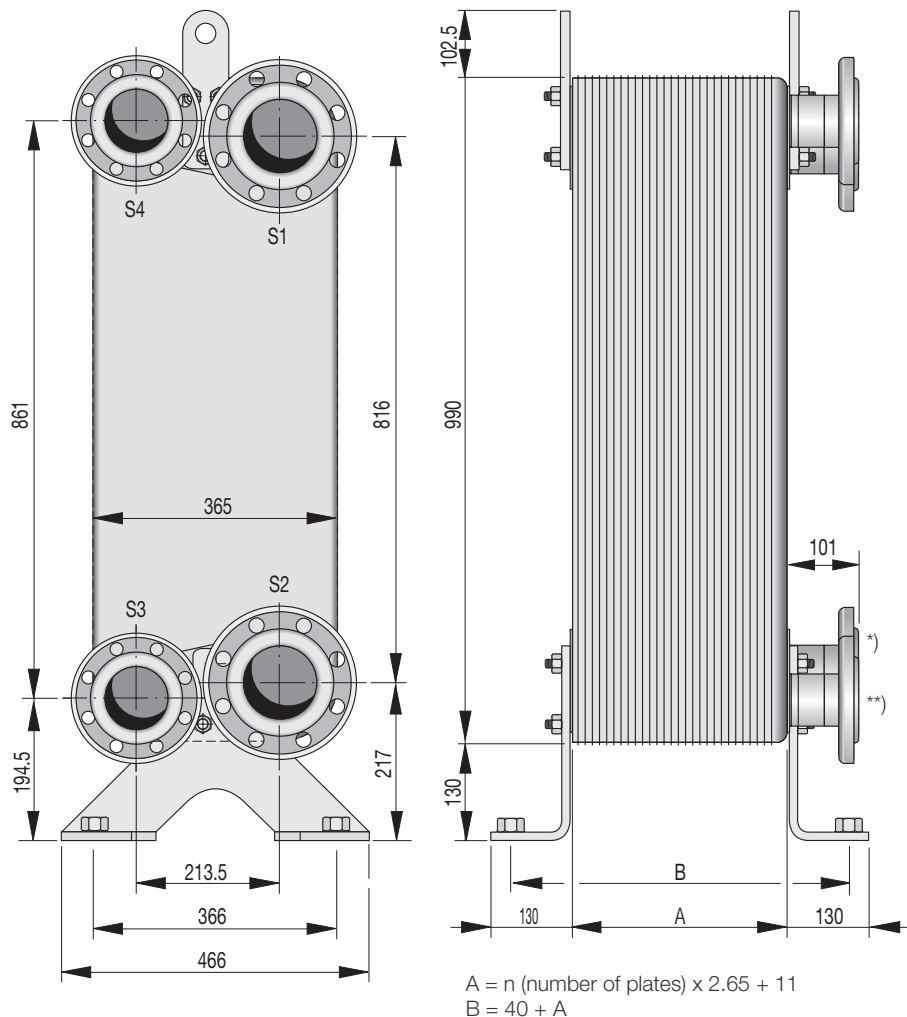

Standard data

Min. working temperature

CE -160°C

Max. working temperature

175°C (for CBR 300: 75°C)

Min. working pressure

Vaccum

Max. working pressure

S1/S2 16 bar

S3/S4 27 bar (for CBR 300: 33 bar)

Volume per channel

0.65 litres

Max. flowrate

S1/S2 140 m³/h

S3/S4 60 m³/h

Weight

40 + n (number of plates) x 1.26 kg

DIN connections

PN25, DN100 *)

PN25, DN65 **)

Connections

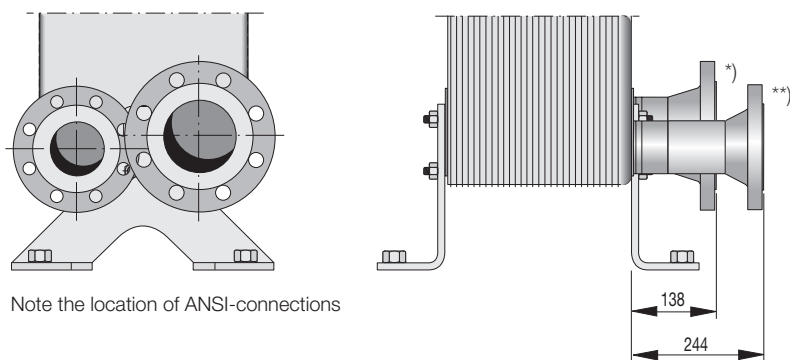

ANSI connections

ANSI 300 Ø 4" *)

ANSI 300 Ø 2.5" **)

PD 68001 E 0203

All rights reserved for changes in specifications

How to contact Alfa Laval

Contact details for all countries are continually updated on our website. Please visit www.alfalaval.com to access the information directly.